

# ***SAFETY FIRST!***

## **Operation & Maintenance Manual XL-62 Vertical Baler**

Standard MODEL  PSR MODEL



***Rotobale Compaction Solutions Inc.***

7232 Arthur Road #5 West, Kenilworth Ontario, N0G 2E0

Ph: 800-565-8027 / Fax: 519-323-3816

[www.rotobalecompaction.ca](http://www.rotobalecompaction.ca)

# Vertical Baler Operating Instructions

- 1) Lay a large flat piece of material inside the bale chamber. It is very important to securely close the bottom door. Tighten the latch wheel by hand only. Do not over tighten by any other method.
- 2) Feed material into the baler. (spreading material out evenly increases bale weight).
- 3) Close the top door (door must not be obstructed by material).
- 4) Press the “Start” button and the ram proceed downward compressing material. At the end of the downward stroke the ram will automatically rise and lift the top door.
- 5) Repeat steps 2, 3, and 4 until the “full” light illuminates.
- 6) When full, press and hold the eject button until the ram reaches the top position.
- 7) Place a large flat piece of material inside the baler on top of the bale being made.
- 8) Close the top door.
- 9) Press the “Start” button. The ram will proceed downward recompressing the bale and the full light will re-activate.
- 10) Turn the “off/on” switch to off.
- 11) With everyone clear from the front of the baler, release the bottom door latch and open the bottom door.
- 12) WORK GLOVES AND SAFETY GLASSES ARE RECOMMENED FOR THIS PROCESS:
  - Standing in front of the baler insert and push the “tie probe” through one of the top slots. The “tie probe” will be guided around the back of the baler and will protrude out at the corresponding bottom slot.
  - Attach cord to the end of the “tie probe” protruding out of the bottom slot. With the cord attached pull the “tie probe” back through and out the top slot.
  - Detach cord and securely tie the two cord ends together.
  - Repeat procedure for all 6 slots.
- 13) Place skid in front of baler.
- 14) Ensure everyone is clear from the front of the baler.
- 15) Turn the “off/on” switch to on.
- 16) To eject bale, stand to the side of the unit then push and hold the “eject” button. The ram will lift the top door up and the bale will automatically eject onto the skid. Release the eject button.
- 17) Congratulations! You just made a bale. Go to step (1).

Equipment sound testing results indicate that hearing protection is not required, however it is recommended that hearing protection be worn while operating the baler.

# Rotobale Compaction Solutions Inc.

## XL- Baler

### Monthly Maintenance Check

#### **Hydraulic System:**

The manufacturer recommends monthly inspection of all hoses and visual inspection of hydraulic components. All inspections must be done with baler disabled. By doing so the user becomes more familiar with the baler, which in turn guarantees early detection of possible problems (E.g.: leaks). When inspecting hoses look for cuts, abrasions and fluid. If any hydraulic fluid is visible, the user should contact the manufacturer. The hydraulic fluid level in the baler reservoir should be maintained at 1½” from the top of the tank, with the ram in the up position. Only a qualified technician should service any components in the hydraulic system. Apply grease to the ram guides and cylinder pin fittings monthly.

#### **Electrical System:**

NOTE: Only a qualified technician should perform work on electrical system.

The person working on these machines should turn the machine off with the stop button. To turn off and lockout the power supply, follow the electrical supply cord from the machine to the disconnect box on the wall. This box should be located within 30 feet of the machine. Pull the handle down or turn the switch to the “off” position to shut off the electricity. Put a padlock through the holes of the handle or switch and lock it so that it cannot be turned on without removing the lock. Only the person locking out the machine should have a key for the padlock. If more than one person is involved, the person who disconnected and locked out the power supply should communicate the purpose and status of the disconnecting and locking out. A non-conducting tag secured in a conspicuous location may serve this purpose. For more guidelines concerning this procedure, refer to the “Occupational Health and Safety Act and Regulations for Industrial Establishments” section.

#### **Warranty:**

All equipment designed and manufactured by Rotobale Compaction Solutions Inc. (RCS) carries a (1) year parts and labour guarantee. A Rotobale waste system is constructed of high-grade materials and is guaranteed to perform on a continued basis at its rated capacity. Any parts that prove defective within (1) year from the date of installation will be replaced without charge, provided the purchaser notifies any such defects to RCS.

Some units may be purchased with extended warranties.

#### **Voiding of Warranty:**

If the contents of this manual are explicitly followed, the operation of the Rotobale waste system is guaranteed. If operations are performed in a matter not in accordance with these instructions and a defect appears, the owner shall make void the warranty that accompanies their Rotobale machine. In addition, defects resulting from Rotobale Compaction Solutions Inc.

# Rotobale Compaction Solutions Inc.

Kenilworth, Ontario, N0G 2E0

Tele (519) 323-3673 Fax: (519) 323-3816

## XI-42/62 Presse Verticale – Le Mode D'emploi

- 1) Étendez un grand morceau plat à l'intérieur du fond de la chambre de compaction. **Il est très important de fermer solidement la porte inférieure.** Serrez la roue du verrou à la main seulement. Ne serrez pas d'aucune autre méthode.
- 2) Introduisez le matériel dans la presse. (Le matériel bien répartis augmente également le poids de balle)
- 3) Fermez la porte supérieure. (La porte ne doit pas être obstruée par le matériel).
- 4) Appuyez sur le bouton de «START» et la RAM procédera en bas comprimant le matériel. À l'extrémité de la course de haut en bas, la RAM automatiquement se lèvera et soulèvera la porte supérieure.
- 5) Répétez les étapes 2, 3 et 4 jusqu'à ce que la lumière «FULL » s'allumine.
- 6) Si plein, appuyez sur et tenez le bouton d'éjection jusqu'à ce que la RAM arrête la position supérieure.
- 7) Placez un grand morceau plat à l'intérieur de la presse sur la balle étant faite.
- 8) Fermez la porte supérieure.
- 9) Appuyez sur le bouton de « START ». La RAM se dirigera vers le bas sur la balle et la «FULL » lumière se réactivera.
- 10) Tournez le commutateur de « off/on » à OFF.
- 11) Lorsque le devant et le derrière du compacteur est libre, libérez le verrou de porte inférieur et ouvrez la porte inférieure.
- 12) PORTEZ LES GANTS EN CUIR ET LES VERRRES DE SÛRETÉ POUR CE PROCESSUS;**
  - Ce tenir devant la presse insérer et pousser la sonde au travers des fentes supérieures au dessus de la balle. La sonde sera guidée autour du dos de la presse et dépassera dehors à la fente inférieure correspondante.
  - Attachez la corde à l'extrémité de la sonde dépassant hors de la fente inférieure. Tirez sur la sonde sur laquelle la corde est attachée. La corde traversant arrière de la balle dépassera dehors à la fente supérieure correspondante.
  - Détachez la corde et attachez solidement les deux extrémités ensemble.
  - Répétez ce procédé pour chacune des 6 fentes.
- 13) Placez une palette devant la presse.
- 14) Assurez que personne ne se trouve devant la presse.
- 15) Tournez le commutateur de « off/on » à dessus.
- 16) Pour éjecter la balle, poussez et tenir le bouton « EJECT» La RAM soulèvera la porte supérieure vers le haut et la balle sera éjecter automatiquement sur la palette Relâcher le bouton d'éjection.
- 17) Félicitations ! Vous avez juste fait une balle. Passez à l'étape

## XI-42/62 Presse Verticale

### Manuel d'entretien

#### **Système hydraulique:**

Le fabricant recommande des inspections régulières de tous les tuyaux et une inspection visuelle des composants hydrauliques. Toutes les inspections doivent être faites pendant que le compacteur est désactivé. En faisant ces inspections, l'utilisateur se familiarise avec le compacteur, ce qui par ailleurs garantit une rapide détection des problèmes potentiels (p. ex., les fuites). En inspectant les tuyaux, vérifiez s'il y a des coupures, des écorchures, du liquide. Vérifiez s'il y a des fuites sur le «bloc d'alimentation» et autour, à tous les joints de tuyaux et à l'intérieur de la partie arrière du compartiment de compactage. S'il remarque du fluide hydraulique, l'utilisateur doit contacter le fabricant. Le niveau de fluide hydraulique dans le réservoir du «bloc d'alimentation» doit être maintenu à deux (2) pouces du haut du réservoir, le piston étant en position arrière. Seul un technicien qualifié doit faire l'entretien des composants du système hydraulique.

#### **Procédures de verrouillage:**

REMARQUE: seul un technicien qualifié doit travailler sur le système électrique  
La personne qui travaille sur ces machines doit arrêter la machine en tournant le bouton d'arrêt. Pour couper et verrouiller l'alimentation électrique, suivez le cordon d'alimentation électrique de la machine jusqu'à la boîte de disjoncteur sur le mur. Cette boîte doit être située à 30 pieds de la machine. Tirez la poignée vers le bas ou mettez l'interrupteur à la position «OFF» (arrêt) pour couper le courant. Enfilez un cadenas dans les orifices de la poignée ou de l'interrupteur et verrouillez le tout de façon qu'il soit impossible de mettre la machine en marche sans enlever le cadenas. Seule la personne qui a verrouillé la machine doit avoir une clé pour ce cadenas. Si plus d'une personne est impliquée, la personne qui a débranché et verrouillé l'alimentation électrique doit communiquer le motif et l'état du débranchement et du verrouillage. Une étiquette en matière non conductrice placée dans un endroit discret peut servir à cette fin. Pour des conseils plus détaillés concernant cette procédure, veuillez consulter la section traitant de la Loi sur la santé et la sécurité au travail – Règlement, établissements industriels.

#### **Garantie:**

Tout équipement conçu et fabriqué par Rotobale Compaction Solutions Inc. (RCS) comporte une garantie d'un (1) an, pièces et main-d'oeuvre. Les systèmes de déchets Rotobale sont construits de matériaux de qualité supérieure et leur fonctionnement continu à capacité nominale est garanti. Toute pièce qui s'avère défectueuse dans un délai d'un (1) an à compter de la date de son installation sera remplacée sans frais, pourvu que l'acheteur informe RCS des défauts constatés. Certaines unités peuvent être achetées avec garantie prolongée.

#### **Annulation de garantie:**

Si les instructions de ce manuel sont expressément mises en pratique, le fonctionnement du système de compaction Rotobale est garanti. Toutefois, si l'exploitation du système est effectuée d'une manière non conforme avec les présentes instructions et qu'un défaut apparaît dans le système de compactage de déchet, le propriétaire rend nulle la garantie qui accompagne sa machine Rotobale. En outre, les défauts résultant de travaux d'entretien non autorisés par R.C.S ont pour effet de rendre nulle la garantie.

# Declaration of Conformance

## Pre-Start Health and Safety Review Exemption

Machine Name:	<b>Vertical Baler</b>
Machine Model:	<b>XL – Series (XL-42 / XL-62)</b>

Based on the safety component installation instructions and electrical drawings provided, the above items are in compliance with the following standards;

Description	Standards requirement met for compliance
Safety control circuit design	Is in accordance with the manufacturer requirements and CSA Z432, Clause 8.2 Safety control system performance criteria.
Emergency stop	Is in accordance with NFPA 79 Electrical Standard for Industrial Controls, Clause 9.5.2 Stop Functions – Category <0,1>

Rotobale Compaction Solutions Inc declares that the above noted machine has been designed and constructed in accordance with the following standards:

- CAN/CSA Z432-16 – Safeguarding of Machinery
  - ISO 13849-1 - Safety of machinery — Safety-related parts of control systems - Part 1: General principles for design
- CAN/CSA C22.1 – Canadian Electrical Code, Part 1
- SPE-1000 - Model Code for the Field Evaluation of Electrical Equipment

Rotobale Compaction Solutions Inc also declares that the protective elements employed on this machine have been installed according to the manufacturer's instructions.

This document can be used as a declaration that forms a Pre-Start Health and Safety Review Exemption as required by Ontario Regulation 851, Section 7, subsection 10.

This document must be kept readily available in the workplace for as long as the protective element remains or is used in the workplace.

**Rotobale Compaction Solutions**  
7232 Arthur Side Road # 5 West,  
Kenilworth, Ontario N0G 2E0  
Tele: (519) 323-3673 Fax: (519) 323-3816



## XL-Series Baler - Annual Inspection Report

Customer Name \_\_\_\_\_

Make/Model of Equipment \_\_\_\_\_

Inspection Date \_\_\_\_\_

Serial# \_\_\_\_\_

Inspected By \_\_\_\_\_

<b><u>Electrical Inspection Point</u></b>	<b>Good</b>	<b>Needs Repair</b>	<b>Comments</b>
Check On / Off Switch			
Check Electrical Connections			
Check Start Button			
Check Eject Button			
Check Full & Power Indicator Lights			
Check Main Supply & Control Fusing Size			
Check Door Switches			
Check Emergency Stop Button			

<b><u>Hydraulic Inspection Point</u></b>	<b>Good</b>	<b>Needs Repair</b>	<b>Comments</b>
Check Cylinder Lugs			
Check Cylinder Extend Hoses			
Check Cylinder Retract Hoses			
Check Ejector Hoses			
Check Cylinder Shaft Seals			
Check Pump Suction / Pressure Hoses			
Check Ejector Valve (Leaks)			
Check Directional Control Valve (Leaks)			
Check Pump (Pressure Test, No Leaks)			
Check Relief Valve (Pressure Test)			
Check Full Pressure Setting			
Check Hydraulic Oil Level (Down 2")			

<b><u>Baler Inspection Points</u></b>	<b>Good</b>	<b>Needs Repair</b>	<b>Comments</b>
Check Hinges & Grease			
Check Cylinder Pins Secure & Grease			
Check Welded Area for Stress Cracks			
Check Anchor Bolts Secured			
Check Ram Wear Strips			
Check & Grease Door Latch & Turnbuckle			
Check Door Chains & Mounting Brackets			
Check Top Door & Counterweights			
Check Door Pulley Assembly			
Check Ejector Assembly			
Check Bale Tie Probe			
Check Top Door Anti-Lift Provisions			

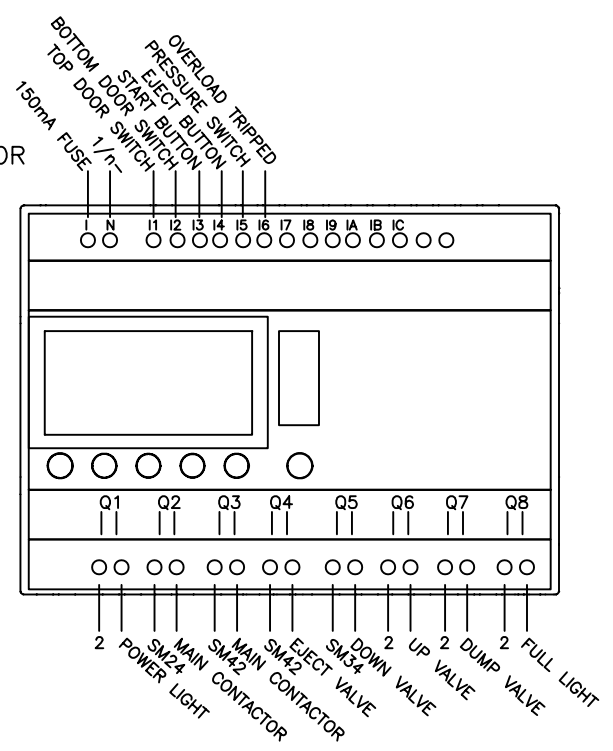
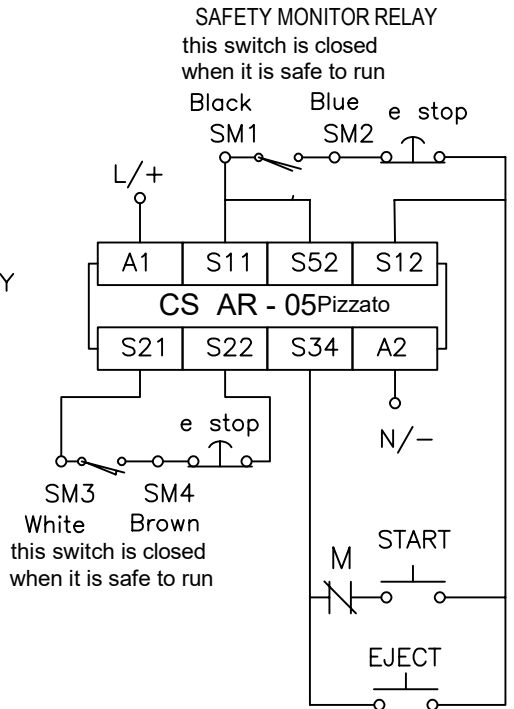
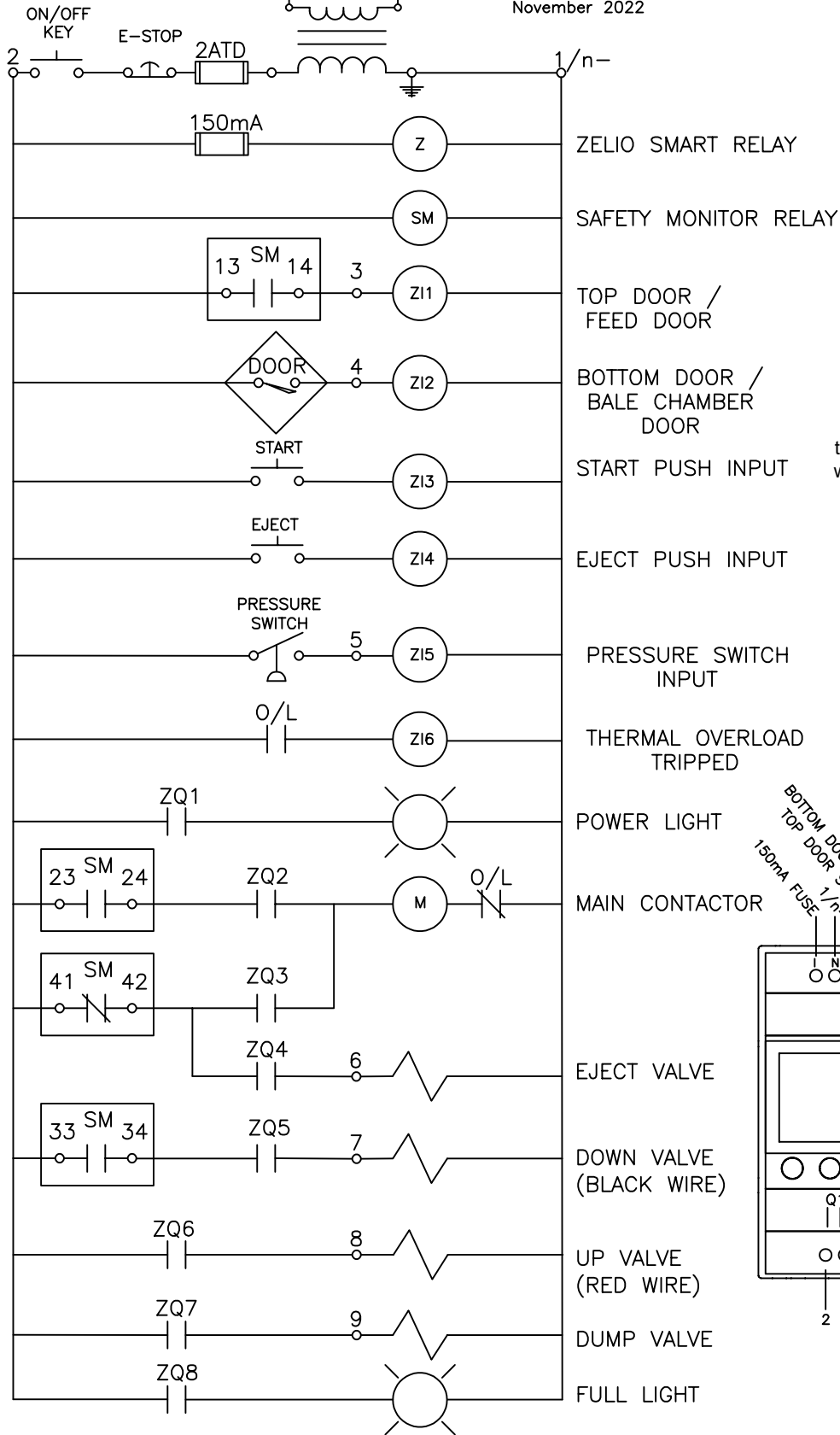
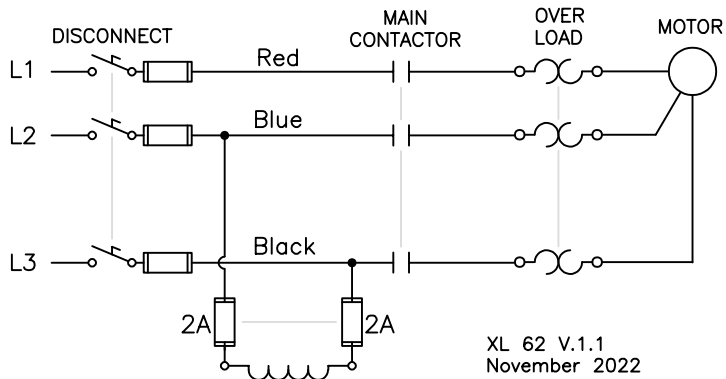



# ROTOBALE COMPACTION SOLUTIONS

# XL - 62 HYDRAULICS

PARTS	DESCRIPTION	PARTS	DESCRIPTION
HOSES			
4) @ $\frac{3}{8}$ X 78 $\frac{3}{8}$ + $\frac{1}{2}$ ENDS	T TO MANIFOLD A+B HOSE	1) CYLINDER @ $3\frac{1}{2}$ X 16	EJECTOR CYLINDER
4) @ $\frac{3}{8}$ X 23 $\frac{3}{8}$ ENDS	CYL A+B HOSE Right side	4) CYLINDER @ 4 X 31	RAM CYLINDERS
4) @ $\frac{3}{8}$ X 20 $\frac{3}{8}$ ENDS	CYL A+B HOSE Left side		
1) @ $\frac{3}{4}$ X 26 $\frac{3}{4}$ ENDS	SUCTION HOSE	VALVE - 85003093	DUMP VALVE
1) @ $\frac{1}{2}$ X 18 $\frac{1}{2}$ ENDS	P - HOSE	VALVE - WE 42 GO 2B3 - A110	EJECTOR VALVE
1) @ $\frac{1}{4}$ X 30 $\frac{1}{4}$ ENDS	EJECTOR P - HOSE	VALVE - WE 43 GO 3C60 - A110	RAM VALVE
1) @ $\frac{1}{4}$ X 154 $\frac{1}{4}$ ENDS	A - EJECTOR CYL HOSE		
1) @ $\frac{1}{4}$ X 138 $\frac{1}{4}$ ENDS	B - EJECTOR CYL HOSE	MANIFOLD ROTOBALE # 1	EJECTOR MANIFOLD
		MANIFOLD ROTOBALE # 5	RAM MANIFOLD
		RELIEF 85002129	MAIN RELIEF
		215 FRAME 1800 RPM	MOTOR
		R 100 $1\frac{3}{8}$ X $\frac{5}{8}$	COUPLING
		A-MOUNT $5\frac{5}{8}$	BELL HOUSING
		HAIR 22 - 10 HP	HYDRAULIC PUMP

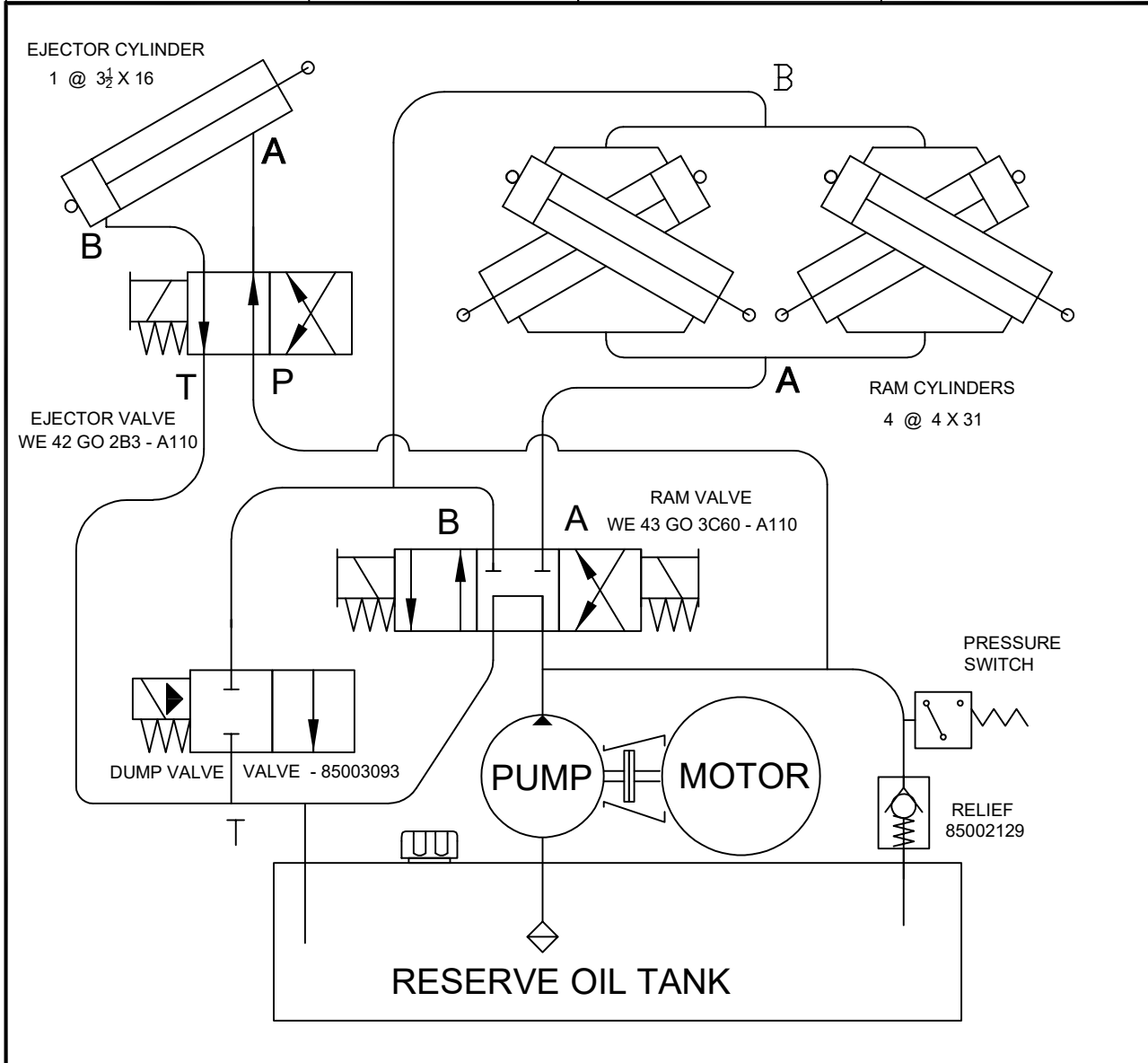

# XL-62 Baler Hoses

	Part Number	Description	Jan 2018
4) @ $\frac{1}{2}$ X 78 $\frac{3}{8}$ + $\frac{1}{2}$ ENDS	03 - 168 - 01	T TO MANIFOLD A+B HOSE	
4) @ $\frac{3}{8}$ X 23 $\frac{3}{8}$ ENDS	03 - 164 - 01	CYL A+B HOSE Right Side	
4) @ $\frac{3}{8}$ X 20 $\frac{3}{8}$ ENDS	03 - 163 - 01	CYL A+B HOSE Left Side	
1) @ $\frac{3}{4}$ X 26 $\frac{3}{4}$ ENDS	03 - 218 - 01	SUCTION HOSE	
1) @ $\frac{1}{2}$ X 18 $\frac{1}{2}$ $\frac{1}{2}$ ENDS	03 - 173 - 01	P - HOSE	
1) @ $\frac{1}{4}$ X 30 $\frac{1}{4}$ ENDS	03 - 110 - 01	EJECTOR P - HOSE	
1) @ $\frac{1}{4}$ X 154 $\frac{1}{4}$ ENDS	03 - 130 - 01	A - EJECTOR CYL HOSE	
1) @ $\frac{1}{4}$ X 138 $\frac{1}{4}$ ENDS	03 - 120 - 01	B - EJECTOR CYL HOSE	

$\frac{1}{4}$  turn changes psi 100 lbs on both relief and pressure switch

## All Hoses in Bin W - 2

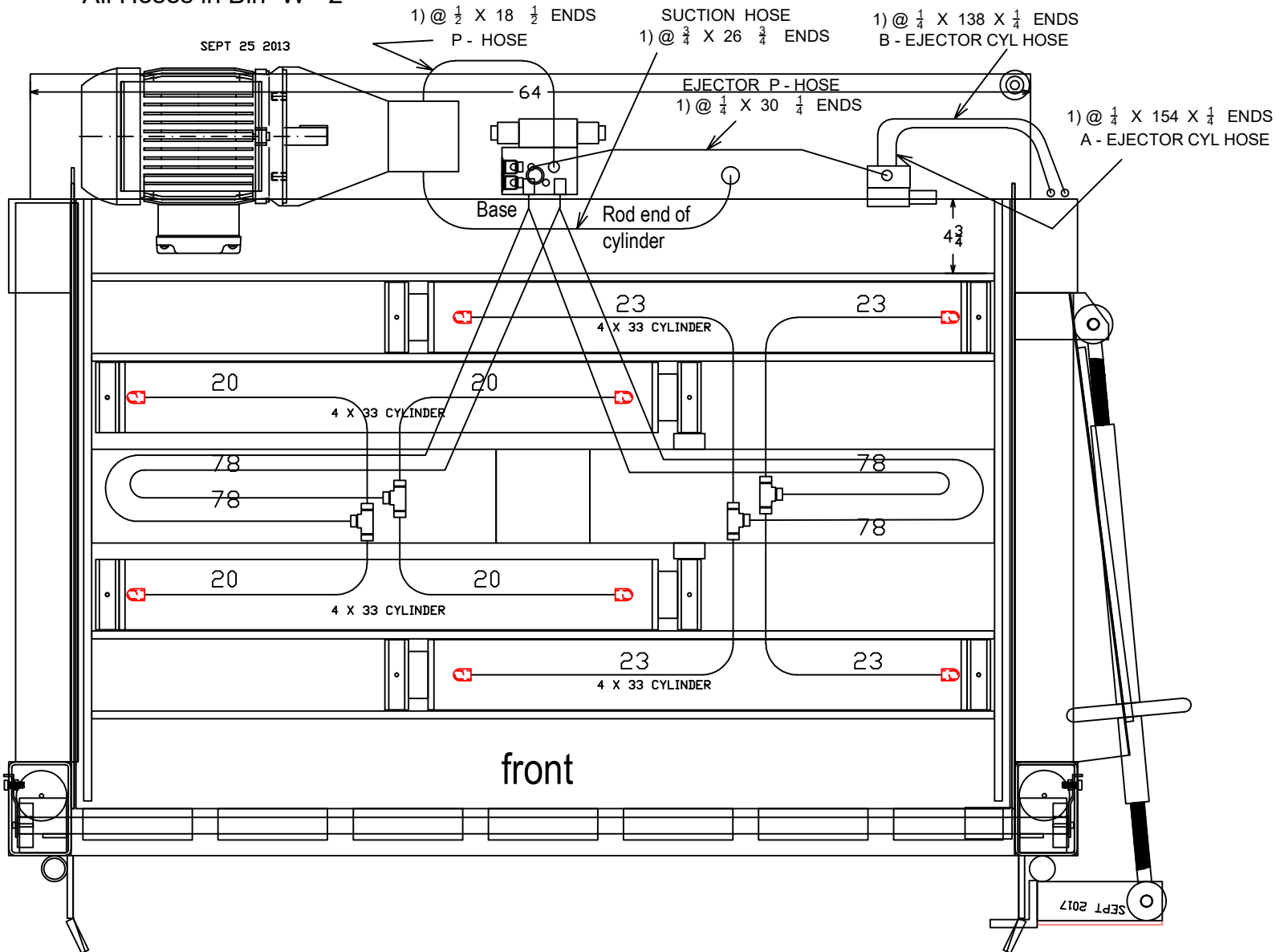

## NOCOLUBE AW SERIES

# Product Data Sheet

## NOCOLUBE AW SERIES

NOCOLUBE AW Series are premium hydraulic fluids formulated from high quality paraffinic base oils that meets severe pump requirements of all major manufacturers. NOCOLUBE AW Series provides outstanding anti-wear protection. The oils will provide excellent long service life under severe industrial and mobile hydraulic applications.

### Typical Approvals

Vickers I-286-S, M-2950-S	AFNOR NF-E 48-690/1
Cincinnati Milacron P-68, P-69, P-70	AFNOR E 48-603 HM
Denison HF-0	ISO 11158 TYPE HM
DIN 51524, Part 2	

### GENERAL CHARACTERISTICS

NOCOLUBE AW	32	46	68	100	220
Product Code	NOC1657	NOC1658	NOC1659	NOC2778	NOC2779
Appearance	Light Pale	Light Pale	Light Pale	Light Pale	Dark Pale
Flash Pt., COC °C	212	226	234	242	258
Pour Point, °C	-24	-24	-18	-15	-15
Viscosity					
CST @ 40°C	32.0	46.0	68.0	100.0	220.0
CST @ 100°C	5.4	6.7	8.5	11.1	18.7
Rust ASTM D 665B	Pass	Pass	Pass	Pass	Pass
Copper Strip Corrosion	1A	1A	1A	1A	1A
Oxidation Life (hours), ASTM D-943	2500+	2500+	2500+	ND	ND
Viscosity INDEX	104	104	107	95	93

### FEATURES

- Outstanding Thermal Stability
- Long Service Life
- Superior Hydrolytic Stability
- Excellent Remissibility
- Low Pour Point
- Qualified Products

### BENEFITS

- Reduces sludge and sticking problems in close tolerance components
- Provides superior system cleanliness with reduced oxidation
- protects against rust and corrosion
- Works well when, contaminated with a small amount of water.  
Readily separates large amounts of water
- Good low temperature performance
- Proven field performance

**Don't pollute! Dispose of used oil properly!**

Call your NOCO sales representative for details on our Oil Recovery Program.

All reasonable care has been taken to ensure that the above information is accurate as of the date of printing.

NOCO Energy CORP.  
Tonawanda, NY 14150  
(800) 500-6626

DATE

16 / 03 / 2019

# Product Data Sheet

## NOCO MULTI-PURPOSE EP#2

**NOCO MULTI-PURPOSE EP#2** is compatible with the most popular greases in use today, including Aluminum complex, calcium, calcium complex and lithium grease. It is not compatible with barium Ben tone or poly urea greases.

**NOCO MULTI-PURPOSE EP#2** is multi-purpose, premium quality grease made from high viscosity Index base oils and a lithium complex soap thickener system. Because of its outstanding performance Properties, it can be used for the lubrication of machinery under heavy loads and high temperatures in a wide range of automotive, industrial, agricultural, mining and construction applications.

**NOCO MULTI-PURPOSE EP#2** can be used to lubricate plain ball and roller bearings in equipment Operating from slow to high speeds and at temperatures ranging from  $-24^{\circ}\text{C}$  ( $15^{\circ}\text{F}$ ) to  $170^{\circ}\text{C}$  ( $365^{\circ}\text{F}$ ).

## TYPICAL PROPERTIES & CHARACTERISTICS

Test Methods	Description	Specification
	NLGI Grade	2
ASTM D 217	Cone penetration @ $77^{\circ}\text{F}$ , worked 60 strokes	265 - 295
ASTM D 128	Thickener Type	Lithium Complex
ASTM D 128	Thickener Content, %	4 - 7
ASTM D 2265	Dropping Point	$168^{\circ}\text{C}$ , ( $360^{\circ}\text{F}$ )
ASTM D 445	Base Oil Viscosity, cut @ $40^{\circ}\text{C}$	175 - 180
ASTM D 2270	Viscosity Index	80 min.
VISUAL	Color	Dark Amber
VISUAL	Appearance	Smooth
ASTM D 2509	Timkin OK Load, lbs.	35 min

**Don't Pollute! Dispose or used oil properly!**

Call your NOCO sales representative for details on our Oil Recovery Program

All reasonable care has been taken to ensure that the above information is accurate as of the date of printing.

NOCO Energy Corp.  
Tonawanda, NY 14150  
(800) 500-6626

# ROTOBALE COMPACTION SOLUTIONS

KENILWORTH, ONTARIO, NOG 2E0,

TEL: 519-323-3673 FAX: 519-323-3816

## XI-62 VERTICAL BALER

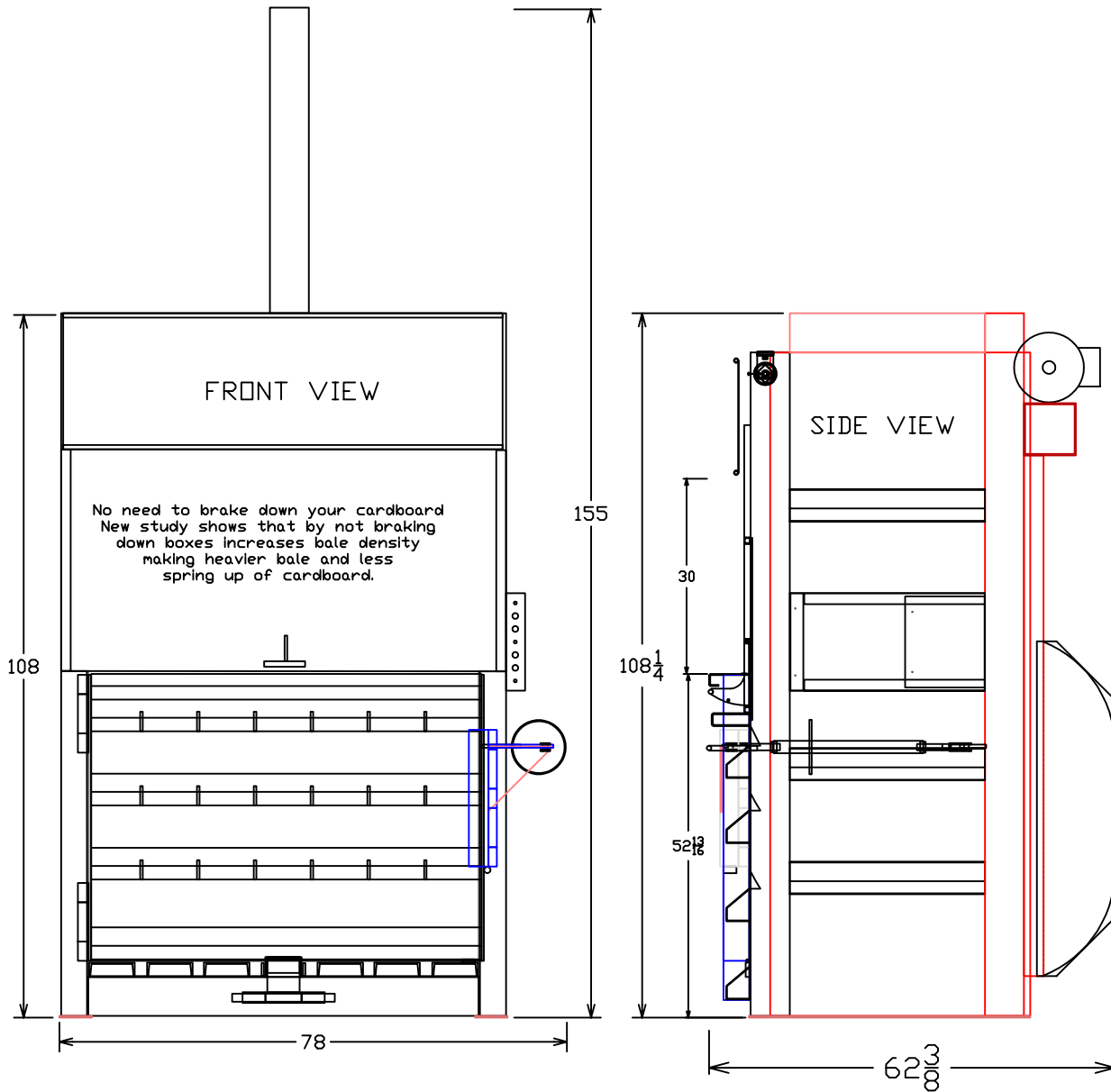

### STANDARD SPECIFICATION

BALE WEIGHT	1500 LBS	BALE TIES	6
MOTOR	5 HP		10 HP
PUMP SIZE	5.4 GPM		10.8 GPM
CYCLE TIME	100 SECONDS		50 SECONDS
VOLTS	208 / 575		208 / 575
AMPS	15 / 6		30 / 12
BALE WIDTH	60"	DEPTH	42"
			HEIGHT 44"

### FEATURES

CLOSED BACK SAVES 1 HOUR ON MAKING BALE AND 6 SQUARE FEET OF FLOOR SPACE, BY ALLOWING BALER TO BE MOVED BACK TO WALL NO MOVING PARTS AT BACK OF BALER INCREASES SAFETY
EMPLOYEE SAFE
LARGE BALE
BALE READY LIGHT
HYDRAULIC EJECTOR
FEED DOOR LIFTS AUTOMATICALLY

SPECIFICATIONS ARE SUBJECT TO CHANGE WITHOUT NOTICE  
TO ACCOMMODATE EQUIPMENT IMPROVEMENTS

# ROTOBALE COMPACTION SOLUTIONS

KENILWORTH, ONTARIO, N0G 2E0, P.O. BOX 100, ARTHUR ROAD # 5

TEL: 519-323-3673 FAX: 519-323-3816

## XL-SERIES VERTICAL BALER

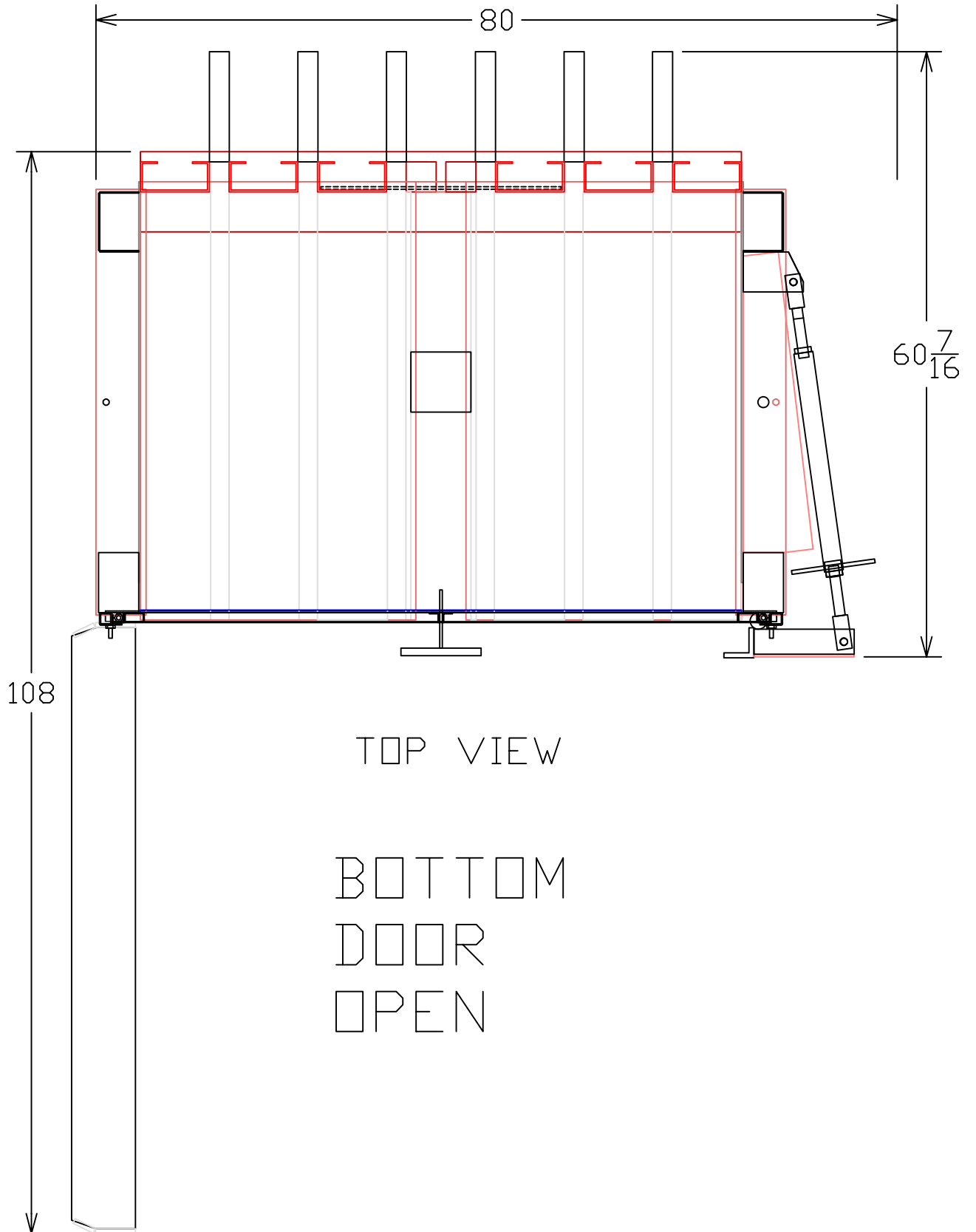

# ROTOBALE COMPACTION SOLUTIONS

KENILWORTH, ONTARIO, N0G 2E0, P.O. BOX 100, ARTHUR ROAD # 5

TEL: 519-323-3673 FAX: 519-323-3816

## XL-SERIES VERTICAL BALER

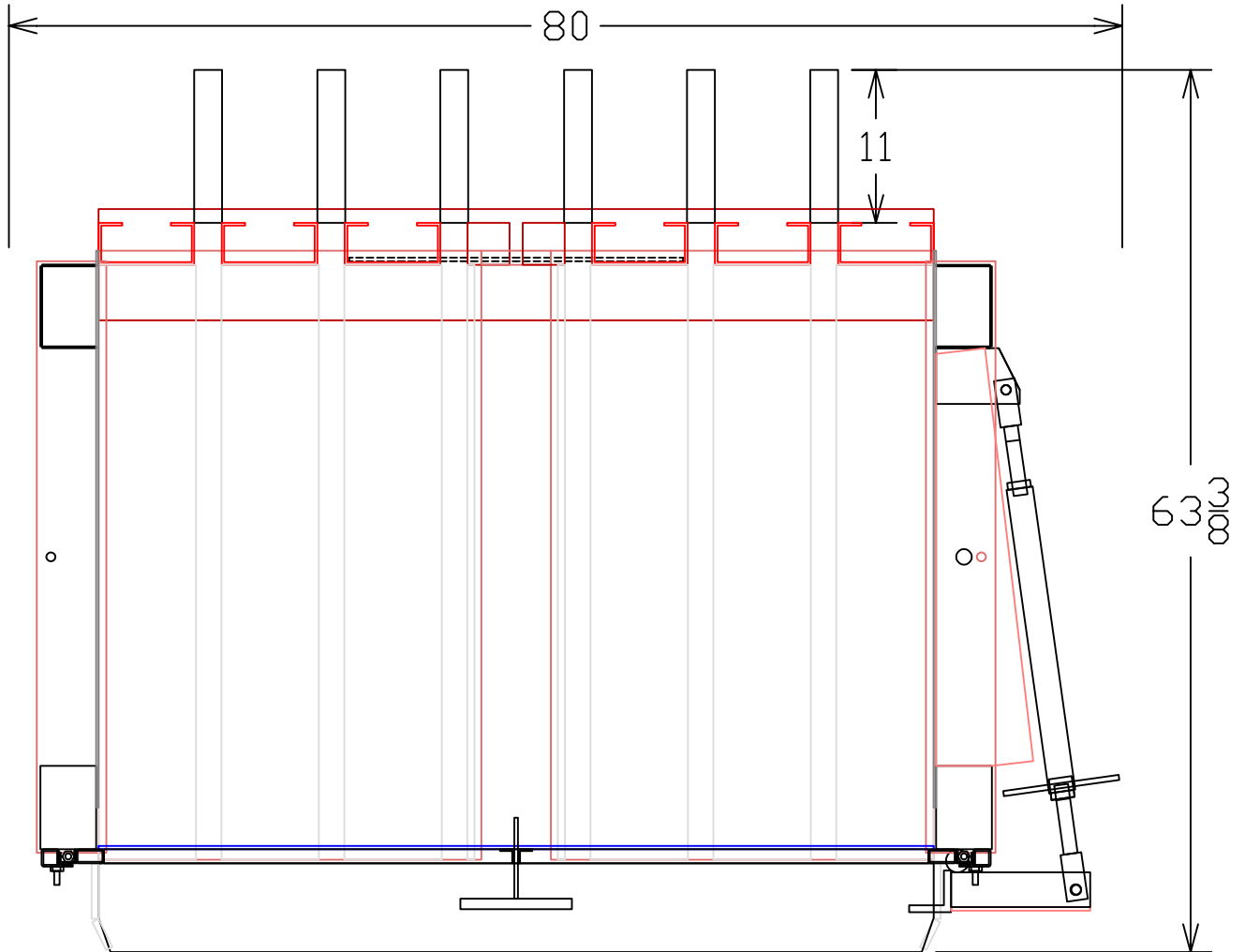

TOP VIEW

BOTTOM  
DOOR  
CLOSED

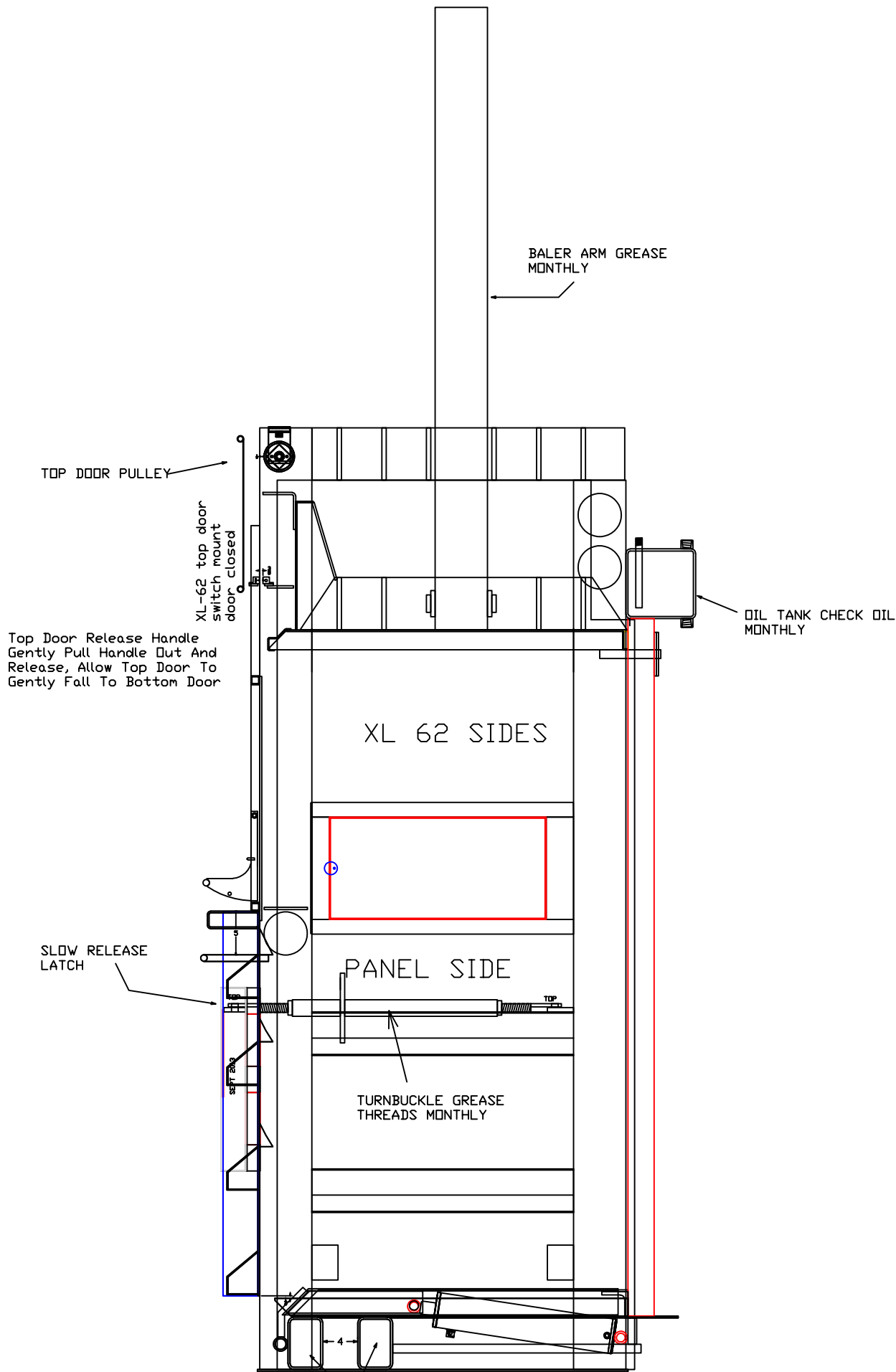

BALER ARM GREASE MONTHLY

TOP DOOR PULLEY

XL-62 top door switch mount door closed

Top Door Release Handle Gently Pull Handle Out And Release, Allow Top Door To Gently Fall To Bottom Door

OIL TANK CHECK OIL MONTHLY

XL 62 SIDES

SLOW RELEASE LATCH

PANEL SIDE

TURNBUCKLE GREASE THREADS MONTHLY

2) 3/8 X 4 X 6 X 60 TB UNDER BALER SUPPORT



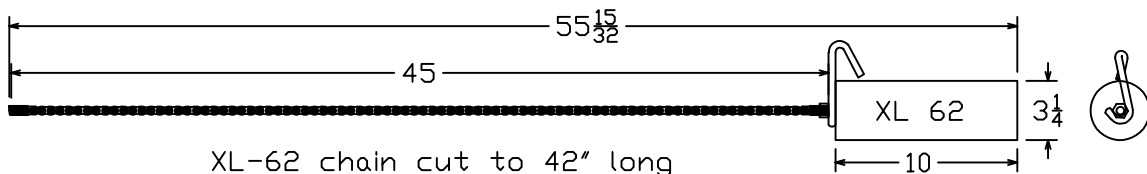
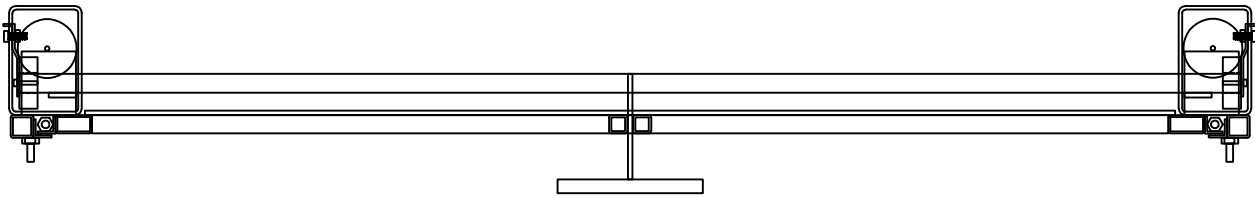
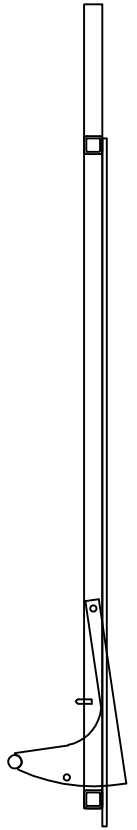
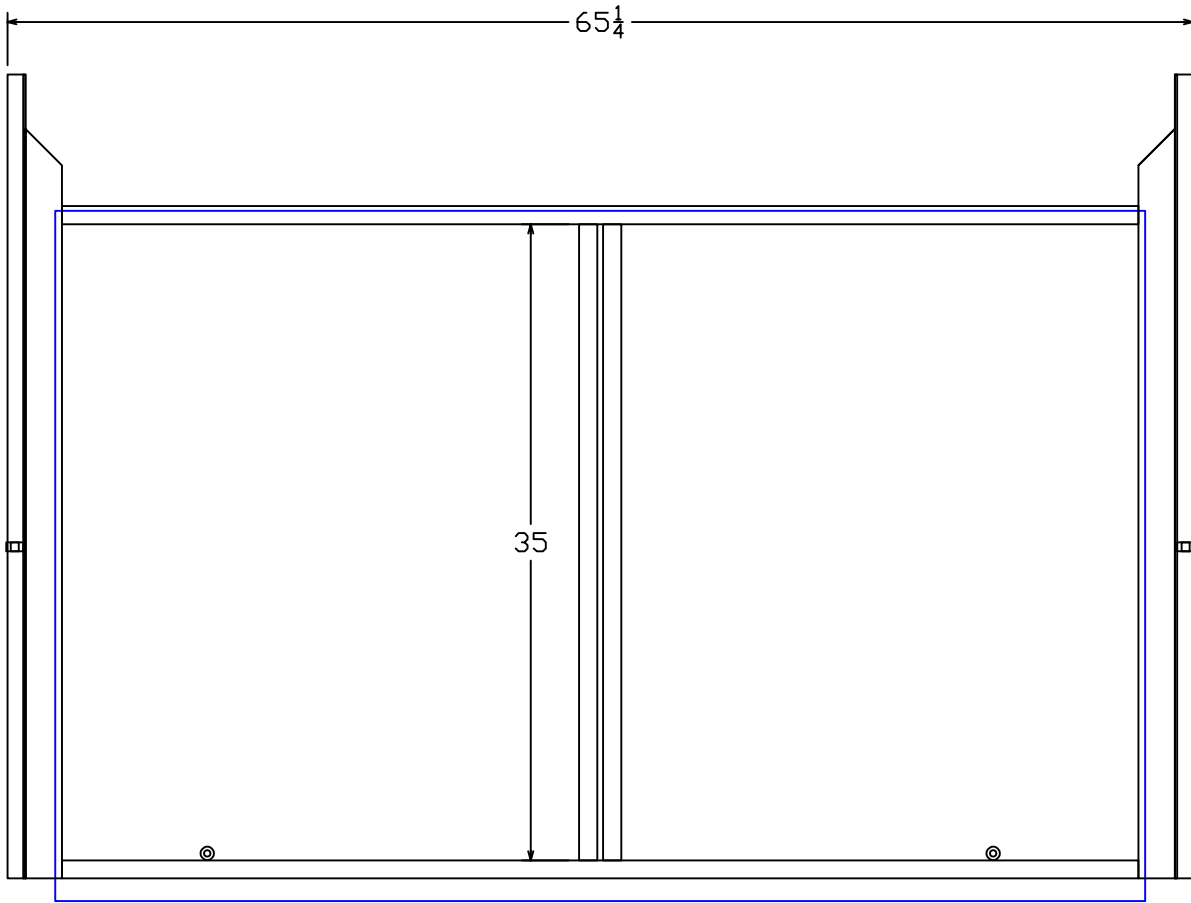

XL-62 chain cut to 42" long  
 with master link and bolt on each end  
 it will be 45" long total July 16 2015  
 Weight is 3 1/4 R.B. 10" long X 2 = 47 lb

2" x 7" fill based on end up in special die  
 and the other end down to 1/8" and backstop at 1/8"

