

ROTOBALE
COMPACTION SOLUTIONS

PACK MORE, SPEND LESS



SAFETY FIRST!
Operation & Maintenance Manual
4260 Stationary Compactor

Standard Model PSR Model



Rotobale Compaction Solutions Inc.

7232 Arthur Road #5 West, Kenilworth Ontario, N0G 2E0

Ph: 800-565-8027/ Fax: 519-323-3816

www.rotobalecompaction.ca

Pre-Start Health and Safety Review Exemption

Project: 13-331	Apparatus: RC-4260 Compactor
Reviewed by: Kevin J. Harris, C.Tech.	Scope: Pre-Start Health and Safety Review
Review Date: Nov. 25/13	Drawing Set: Group: RC-4260 Compactor, Oct. 2009
Issue Date: Nov. 25/13	Date Rec'd: Nov. 7/13

On Nov. 25/13 a review was conducted during the machine design stage to investigate the safety controls proposed for the **RC-4260 Compactor** constructed by Rotobale Compaction Solutions Inc. in Kenilworth, Ontario.

The following list of stakeholders, were present and involved in the review and design process.

Company	Personnel	Title
ProSafe Inc	Kenneth A. Mclsaac, Ph.D., P. Eng	Approving Engineer
ProSafe Inc	Miles Purvis	President
ProSafe Inc	Kevin J. Harris	Project Manager
Rotobale Compaction Solutions	Steve Sequeira	Manager

The people at the design review participated in a Design Review using a series of common evaluation methods as follows.

- 1) CSA Z432 – Safeguarding of Machinery
- 2) EN 954-1 - Safety Related Parts of Control Systems.

The following safeguarding components are employed in the machine and/or system.

- 1) GuardSwitch (by Sentrol Industrial), 301-BT-12K, non-contact coded magnetic interlock
- 2) GE Interlogix, INT-03-120, Safety Monitoring Relay

Based on the safety component installation instructions and electrical drawings provided by Rotobale Compaction Solutions Inc., the following items are in compliance with the relevant standards:

Description	Standards requirement met for compliance
Safety control circuit design	Is in accordance with the manufacturer requirements and CSA Z432, Clause 8.2 Safety control system performance criteria.
Emergency stop	Is in accordance with NFPA 79 Electrical Standard for Industrial Controls, Clause 9.5.2 Stop Functions – Category <0,1,2>

In order to complete the exemption, Rotobale Compaction Solutions Inc. shall provide a letter of declaration to the end user, stating the safeguarding items are installed in accordance with the manufacturer's instructions

This document must be kept readily available in the workplace for as long as the protective element remains or is used in the workplace according to Section 7, subsection 10 of the Regulation.

Approved by:

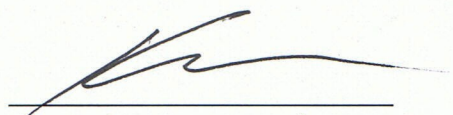
Kenneth A. Mclsaac, Ph.D., P. Eng



Approved for Use/Production

Project:	13-331	Apparatus	RC-4260 Compactor
Review Date:	Nov. 25/13	Scope:	Rotobale Compaction Solutions Inc.
Issue Date:	Nov. 25/13	Approved by:	Kenneth A. Mclsaac, Ph.D. , P. Eng
Reviewed by:	Ken Mclsaac		

A) Safety Circuit Observations:

1. The circuit includes a dual channel e-stop and a dual channel safety switch. Both safety elements are tied into a safety relay that requires manual reset.
2. The magnetic switch removes power from all hazardous motion through a control reliable circuit that requires manual reset.

The Safety Control circuit has been reviewed and approved in accordance with CSA Z432, Clause 8.2 Safety control system performance criteria.

B) Fixed and Interlocked Guarding Observations:

1. An emergency stop button is available to the operator at the main control location.
2. An electrical disconnect is readily available.
3. Sentrol Industrial Guardswitch (Model # 301-BT-12K) interlock switches are provided on the access doors.
4. Operational testing was performed on the interlock gate switches and the emergency stops on both compactor units installed on site.
5. An emergency stop and a magnetic safety switch have been identified in the drawing.
6. Emergency stop stops all hazardous motion through a hardwired circuit that requires manual reset. Emergency stop also removes power from the hydraulic pump.



The fixed and interlocked guarding has been reviewed and approved in accordance with CSA Z432, Clause 10.2 Barrier guards, fixed and interlocked

Reviewed Documents:

- 1) Electrical Wiring Schematics (RC-4260 Compactor, dated Oct. 2009)

The RC-4260 Compactor constructed by Rotobale Compaction Solutions located in Kenilworth, Ontario has been reviewed and approved for use in full production based on a combination of design review and installation verification performed by ProSafe Inc..

Approved by: 
Kenneth A. Mclsaac, Ph.D. , P. Eng



Rotobale Compaction Solutions Inc.

Kenilworth, Ontario, N0G 2E0
Tele (519) 323-3673 Fax: (519) 323-3816

Models RC (Wet) and 4260 (Dry) Compactors

Operation Manual

TO TURN COMPACTOR ON: Illuminated power light indicates power is live to the compactor. To begin compaction cycle insert key in the key switch, turn the key and release. If the compactor does not start, check that the Emergency Stop button is disengaged. If the “Full” light is on (see below). Remove Key when the compactor is not in use

EMERGENCY STOP BUTTON: Press to stop the compactor. The compactor will remain in the ‘off’ mode until the Emergency Stop button is disengaged. To accomplish this; pull the E-stop button up until it clicks and the ‘power’ light will illuminate, allowing the compactor to be started.

¾ FULL LIGHT: This light will turn on when the ram is traveling forward and pressure inside the charging chamber reaches a pre-set limit (1,200 psi).

FULL LIGHT: When pressure inside the charging chamber reaches a pre-set limit, (1,500 psi), the “full light” will illuminate and the compactor will shut off. The container needs to be emptied.

RESET: Turns off the “full and ¾ light” and resets the system to enable start.

REVERSE BUTTON: Cycles ram in reverse direction.

PRESSURE GAUGE: (Optional) Indicates compaction pressure.

MULTI-CYCLE TIMER: (Optional) Allows the ram to continuously run through a pre-set number of complete cycles before the machine shuts off.

DUMPER SYSTEM: (Optional) Used to overturn and dump containers into hopper.

WINCH SYSTEM: (Optional) Used to pull container into place.

Rotobale Compaction Solutions Inc.

Kenilworth, Ontario, N0G 2E0

Tele (519) 323-3673 Fax: (519) 323-3816

Models RC (Wet) and 4260 (Dry) Compactors

Maintenance Manual

Hydraulic System:

The manufacturer recommends regular inspection of all hoses and visual inspection of hydraulic components. All inspections must be done with compactor disabled. By doing so the user becomes more familiar with the compactor, which in turn guarantees early detection of possible problems (E.g.: leaks). While inspecting hoses look for cuts, abrasions and fluid. Look for leaks at and around the 'power pack', at all hose connections and inside the rear of the compaction chamber. If any hydraulic fluid is visible, the user should contact the manufacturer. The hydraulic fluid level in the power pack reservoir should be maintained at 2" from the top of the tank, with the ram in the rear position. Only a qualified technician should service any components in the hydraulic system.

Lockout Procedure:

NOTE: Only a qualified technician. Should perform work on electrical system The person working on these machines should turn the machine off with the stop button. To turn off and lockout the power supply, follow the electrical supply cord from the machine to the disconnect box on the wall. This box should be located within 30 feet of the machine. Pull the handle down or turn the switch to the "off" position to shut off the electricity. Put a padlock through the holes of the handle or switch and lock it so that it cannot be turned on without removing the lock. Only the person locking out the machine should have a key for the padlock. If more than one person is involved, the person who disconnected and locked out the power supply should communicate the purpose and status of the disconnecting and locking out. A non-conducting tag secured in a conspicuous location may serve this purpose. For more guidelines concerning this procedure, refer to the "Occupational Health and Safety Act and Regulations for Industrial Establishments" section

Warranty:

All equipment designed and manufactured by Rotobale Compaction Solutions Inc. (RCS) carries a (1) year parts and labour guarantee. A Rotobale waste system is constructed of high-grade materials and is guaranteed to perform on a continued basis at its rated capacity. Any parts that prove defective within (1) year from the date of installation will be replaced without charge, provided the purchaser notifies any such defects to RCS.

Some units may be purchased with extended warranties.

Voiding of Warranty:

If the contents of this manual are explicitly followed, the operation of the Rotobale waste system is guaranteed. If however operations are performed in a matter not in accordance with these instructions and a defect appears in the waste system, the owner shall make void the warranty that accompanies their Rotobale machine. In addition, defects resulting from service work not authorized by R.C.S. shall render the warranty void.



7232 Arthur Side Rd. #5 West | Kenilworth, Ontario | N0G 2E0
 Phone: 519-323-3673 | Fax: 519-323-3816 | Toll Free: 1-800-565-8027
 Email: info@rotobalecompaction.ca Website: www.rotobalecompaction.ca

RC & 4260 INSPECTION REPORT

Site name _____
 Inspection date _____ Serial number _____

Electrical Inspection Points

COMMENTS

- Key switch _____
- Ram reverse button _____
- Reset button _____
- Full indicator light _____
- ¾ full indicator light _____
- Settings for timer 1, timer 2 & timer 3 _____
- Main supply & control fuse sizing _____
- Gate & door switches _____
- Emergency stop button _____

Hydraulic Inspection Points

- Cylinder extend hoses _____
- Cylinder retract hoses _____
- Cylinder shaft seals _____
- Pump suction / pressure hoses _____
- Hydraulic valve (shifting, no leaks) _____
- Pump (pressure test, no leaks) _____
- Relief valve (pressure test, setting 1,800 psi) _____
- Full Pressure switch (pressure test, setting 1,500 psi) _____
- ¾ full pressure switch (pressure test, setting 1,200 psi) _____
- Hydraulic oil level (down 2") _____
- Water Oil Test _____

Compactor Inspection Points

- Scraper, Slider, Ram, Flapper _____
- Cylinder pins secure _____
- Leg & guide anchor pins _____
- Wall chute & Stand _____
- Shock Absorbent Building Seal _____
- Container clamps _____
- Back side of ram clear of debris _____
- Under charge box clear (RC Only) _____
- Cover Secure _____
- Ram Wear Strips _____

Container Inspection Points

- Wheels Greased & Functioning _____
- Door Latch & Assembly _____
- Door Seal (RC Only) _____
- Hinges greased & functioning _____
- Chain & latch _____
- Rails & Guides _____
- Lift hooks _____

ROTOBALE COMPACTION SOLUTIONS

OCTOBER 2010

KENILWORTH, ONT, NOG 2EO

TEL: 519-323-3673

FAX: 519-323-3816

COMPACTOR
e stop

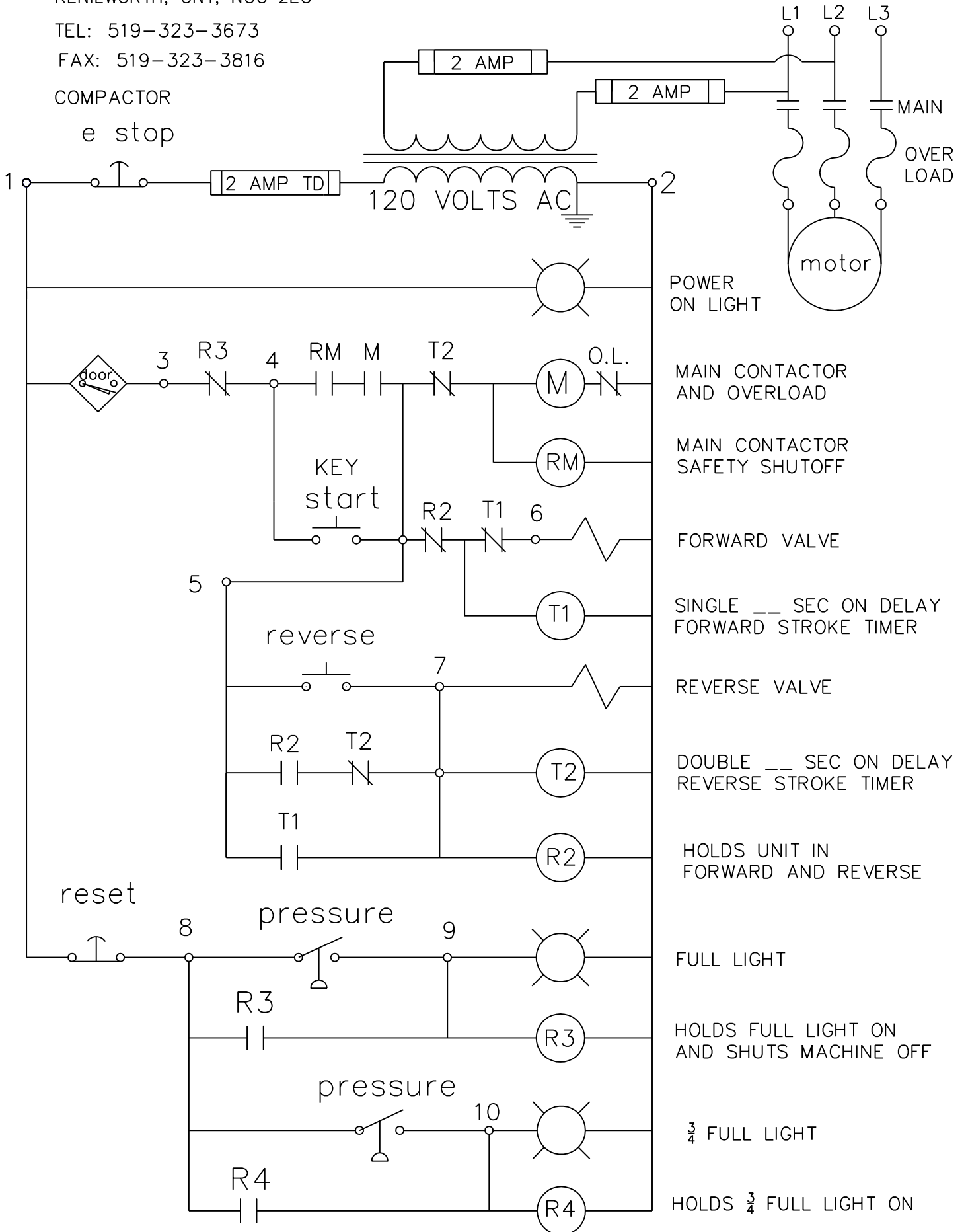

ROTOBALE COMPACTION SOLUTIONS

OCTOBER 2009

KENILWORTH, ONT, NOG 2E0

TEL: 519-323-3673

FAX: 519-323-3816

LEVEL 3 COMPACTOR

e stop

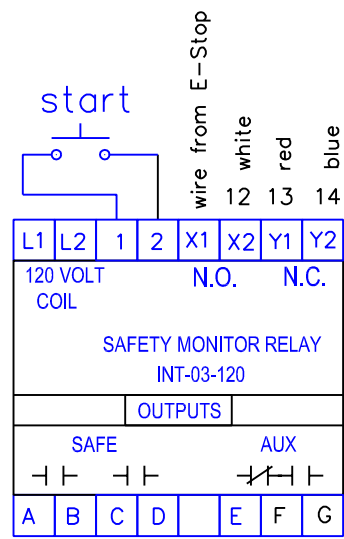
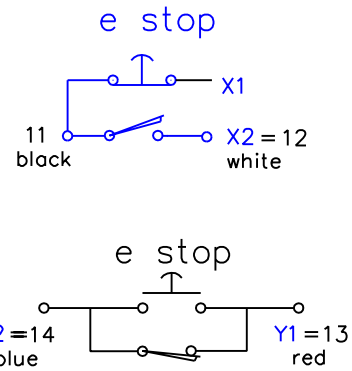
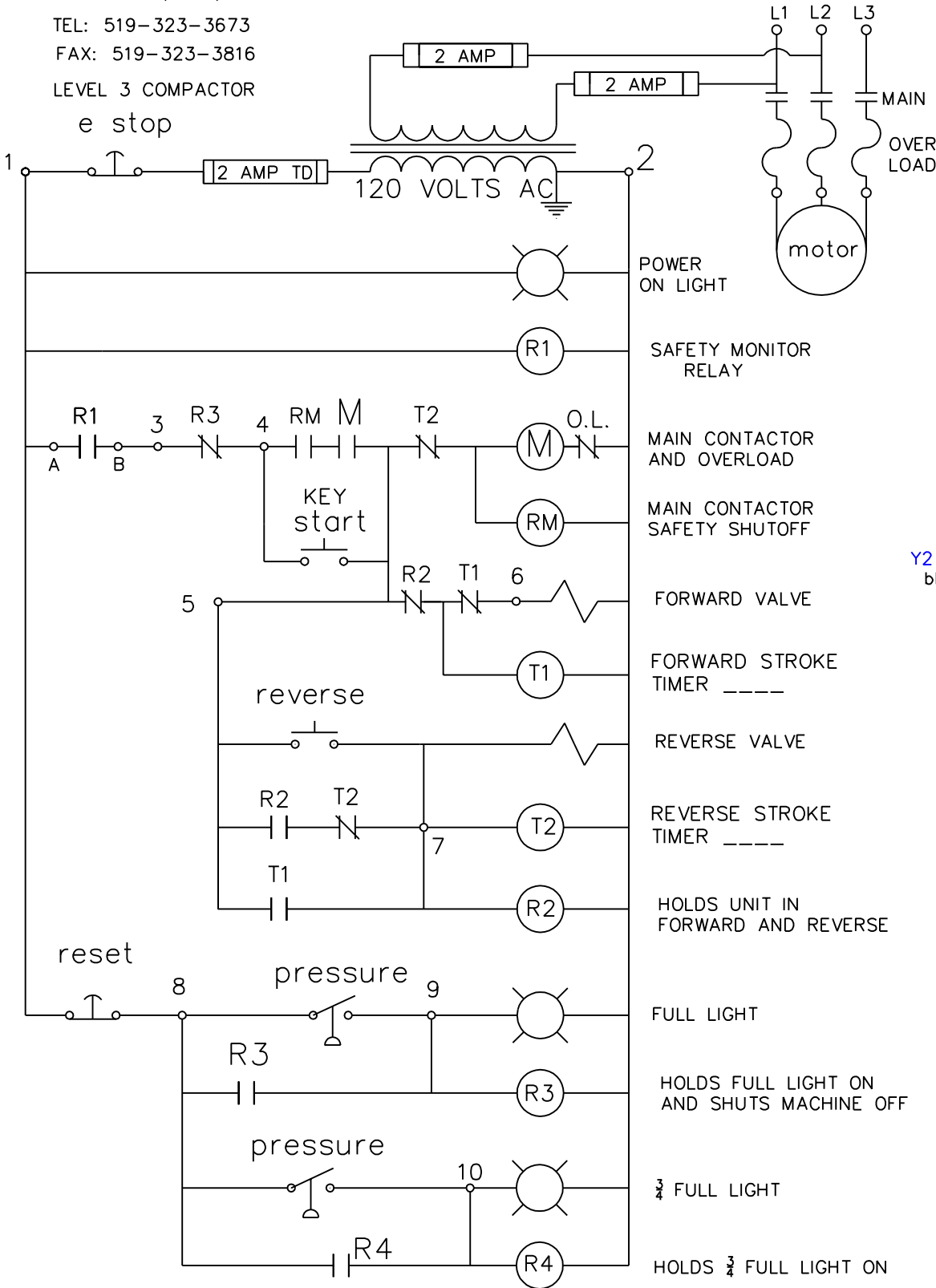

ROTOBALE COMPACTION SOLUTIONS

Compactor Hydraulics

PARTS	DESCRIPTION	PARTS	DESCRIPTION
2) @ $\frac{1}{2}$ " X 42" $\frac{1}{2}$ " ENDS	CYLINDER HOSE	2) CYLINDER @ $4\frac{1}{2}$ " X 42	RAM CYLINDERS
2) @ $\frac{1}{2}$ " X 25 $\frac{1}{2}$ " $\frac{1}{2}$ " ENDS	CYLINDER HOSE		
2) @ $\frac{1}{2}$ " X 28 $\frac{1}{2}$ " ENDS	t - to cupling by quick coupler	VALVE - WE 43 GO 3C3 - A110	RAM VALVE
1) @ $\frac{1}{2}$ " X 18 $\frac{1}{2}$ " ENDS	P - HOSE	MANIFOLD ROTOBALE # 5	RAM MANIFOLD
1) @ $\frac{3}{4}$ " X 26 $\frac{3}{4}$ " ENDS	SUCTION HOSE	RELIEF 85002129	MAIN RELIEF
215 FRAME 1800 RPM	MOTOR	SW1 DMIC	PRESSURE SWITCH
R 100 $\frac{1}{2}$ " X $\frac{1}{2}$ "	COUPLING		
A-MOUNT 5 $\frac{1}{2}$ "	BELL HOUSING		
HAIR 22 - 10 HP	10 Gal Hydraulic Pump		

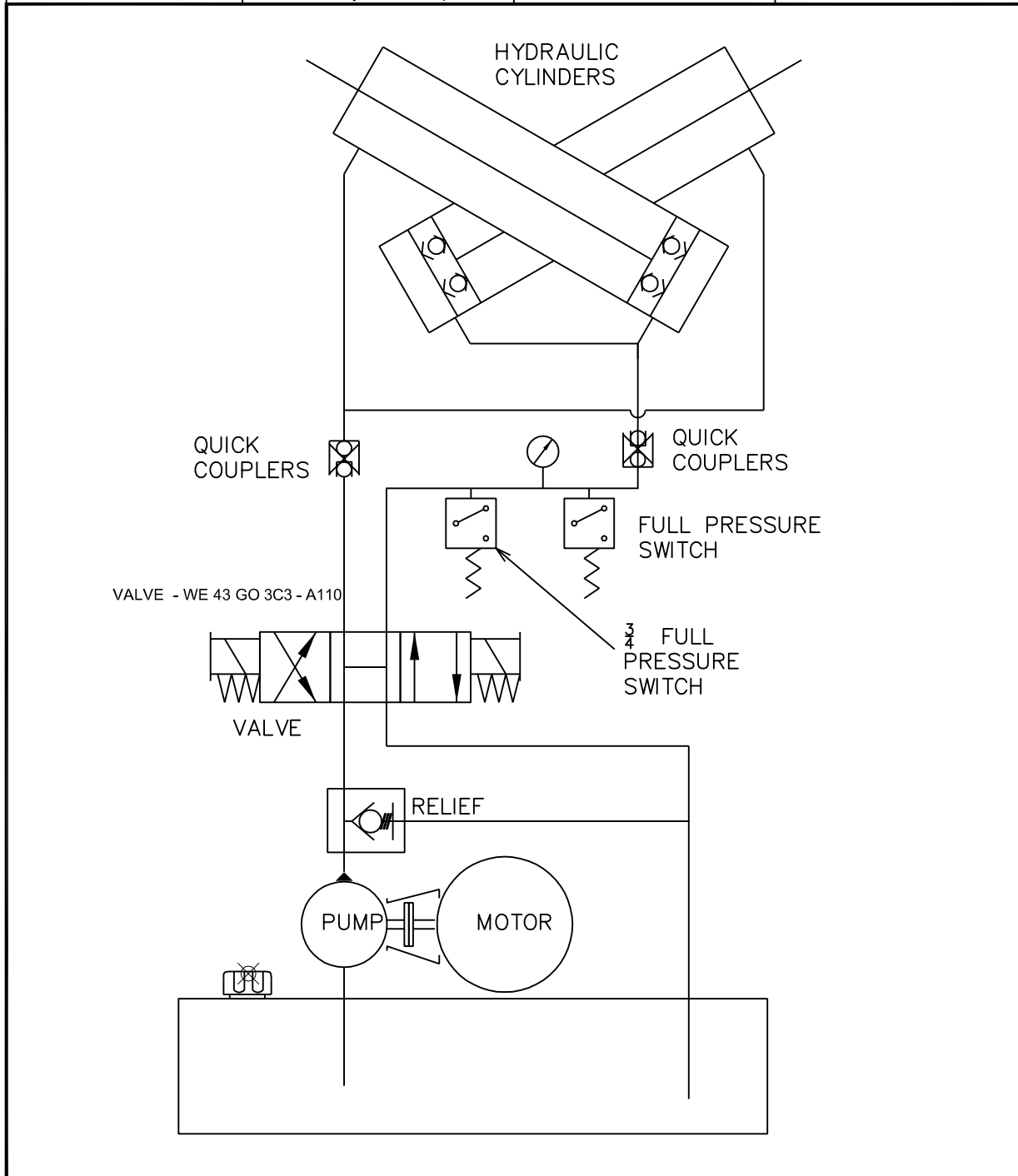

ROTOBALE COMPACTION SOLUTIONS

PHONE 519-323-3673 FAX 519-323-3816

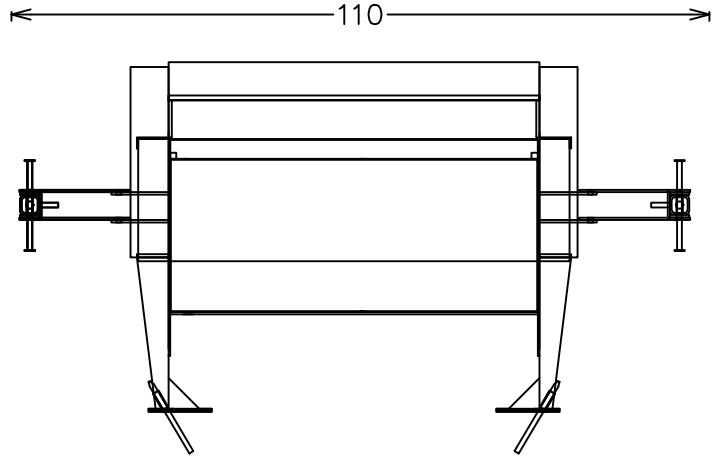
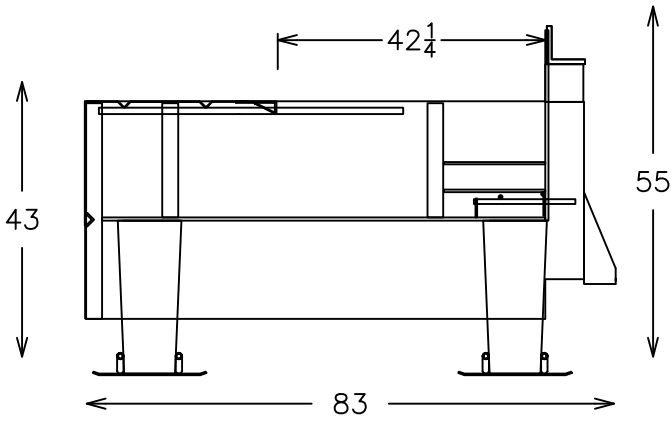

Standard Specification's Model 4260

Attached Bin Size	40-YD	50-YD
CARDBOARD WEIGHT APPROX.	4 TON	5 TON
WASTE WEIGHT APPROX.	12 TON	16 TON
RAM PENETRATION	16" (WITHIN CONTAINER)	
MOTOR	5 HP	10 HP
PUMP SIZE	5.4 GPM	10.8 GPM
CYCLE TIME	90 SECONDS	45 SECONDS
VOLTS	208 / 575	208 / 575
AMPS	15 / 6	30 / 12

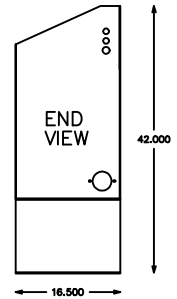
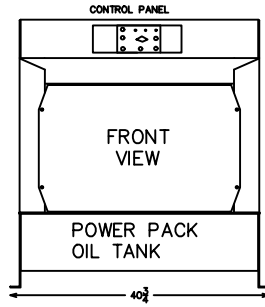

SPECIFICATIONS ARE SUBJECT TO CHANGE WITHOUT NOTICE
TO ACCOMODATE EQUIPMENT IMPROVEMENTS

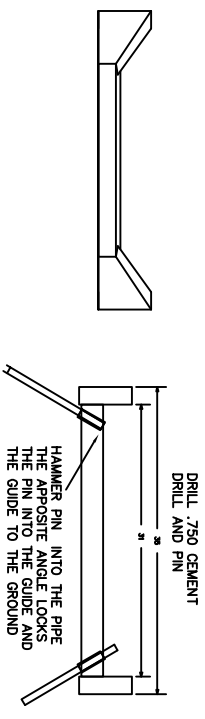
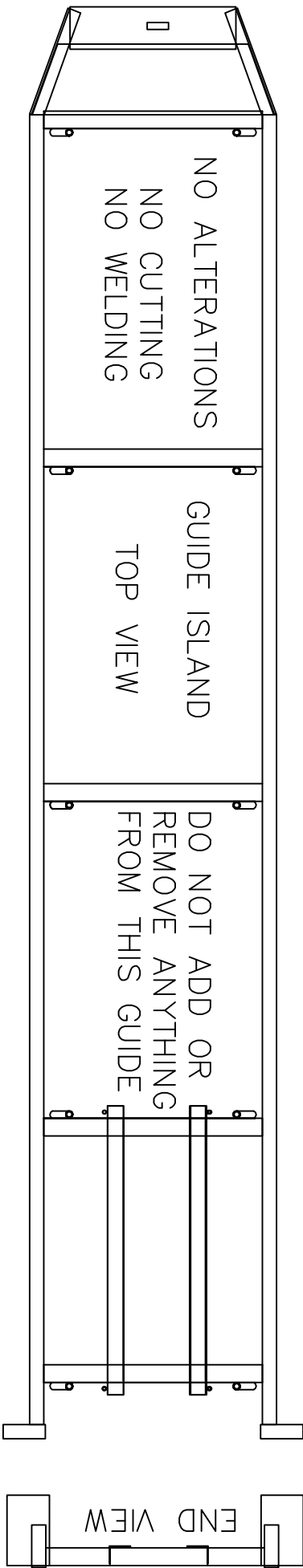

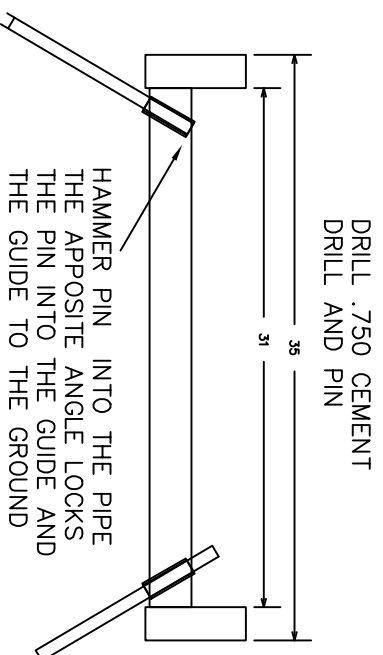

NO ALTERATIONS
NO CUTTING
NO WELDING

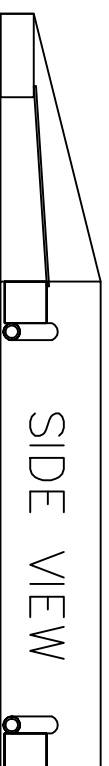
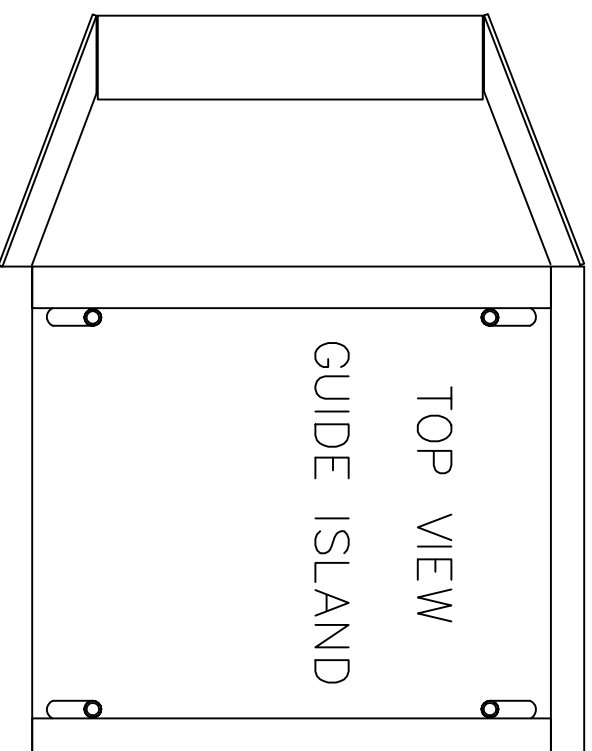

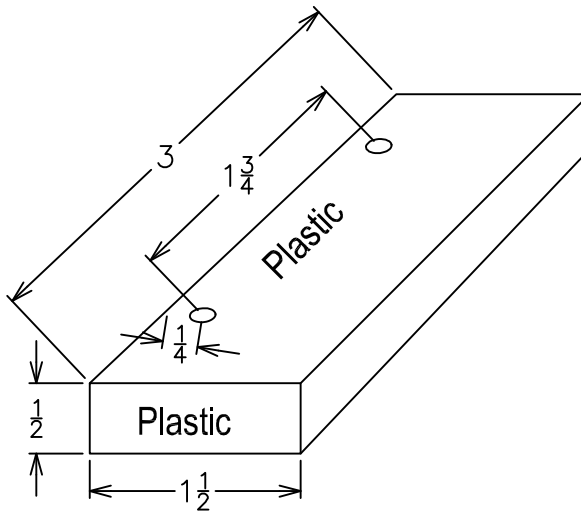
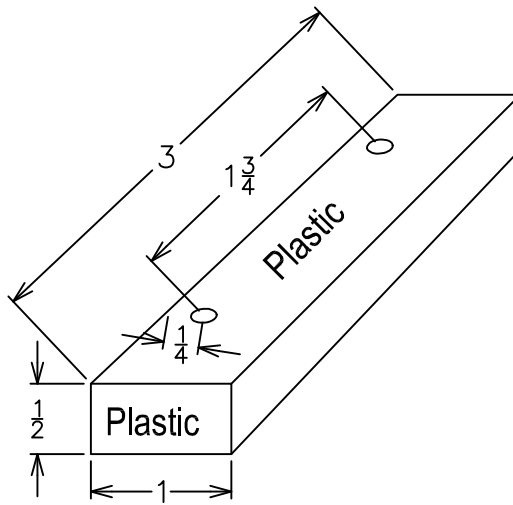

Must hold $\frac{3}{8}$ " apart and must be aligned straight

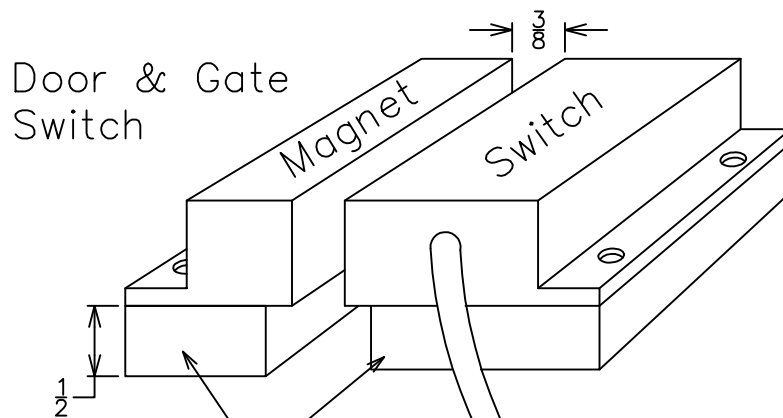

Must Have $\frac{1}{2}$ Inch Of Plastic To Insulate the Magnetic Field From Steel

Wire

NOCOLUBE AW SERIES

Product Data Sheet

NOCOLUBE AW SERIES

NOCOLUBE AW Series are premium hydraulic fluids formulated from high quality paraffinic base oils that meets severe pump requirements of all major manufacturers. NOCOLUBE AW Series provides outstanding anti-wear protection. The oils will provide excellent long service life under severe industrial and mobile hydraulic applications.

Typical Approvals

Vickers I-286-S, M-2950-S	AFNOR NF-E 48-690/1
Cincinnati Milacron P-68, P-69, P-70	AFNOR E 48-603 HM
Denison HF-0	ISO 11158 TYPE HM
DIN 51524, Part 2	

GENERAL CHARACTERISTICS

NOCOLUBE AW	32	46	68	100	220
Product Code	NOC1657	NOC1658	NOC1659	NOC2778	NOC2779
Appearance	Light Pale	Light Pale	Light Pale	Light Pale	Dark Pale
Flash Pt., COC °C	212	226	234	242	258
Pour Point, °C	-24	-24	-18	-15	-15
Viscosity					
CST @ 40°C	32.0	46.0	68.0	100.0	220.0
CST @ 100°C	5.4	6.7	8.5	11.1	18.7
Rust ASTM D 665B	Pass	Pass	Pass	Pass	Pass
Copper Strip Corrosion	1A	1A	1A	1A	1A
Oxidation Life (hours), ASTM D-943	2500+	2500+	2500+	ND	ND
Viscosity INDEX	104	104	107	95	93

FEATURES

- Outstanding Thermal Stability
- Long Service Life
- Superior Hydrolytic Stability
- Excellent Remissibility
- Low Pour Point
- Qualified Products

BENEFITS

- Reduces sludge and sticking problems in close tolerance components
- Provides superior system cleanliness with reduced oxidation
- protects against rust and corrosion
- Works well when, contaminated with a small amount of water. Readily separates large amounts of water
- Good low temperature performance
- Proven field performance

Don't pollute! Dispose of used oil properly!

Call your NOCO sales representative for details on our Oil Recovery Program.

All reasonable care has been taken to ensure that the above information is accurate as of the date of printing.

NOCO Energy CORP.
Tonawanda, NY 14150
(800) 500-6626

DATE

16 / 03 / 2015

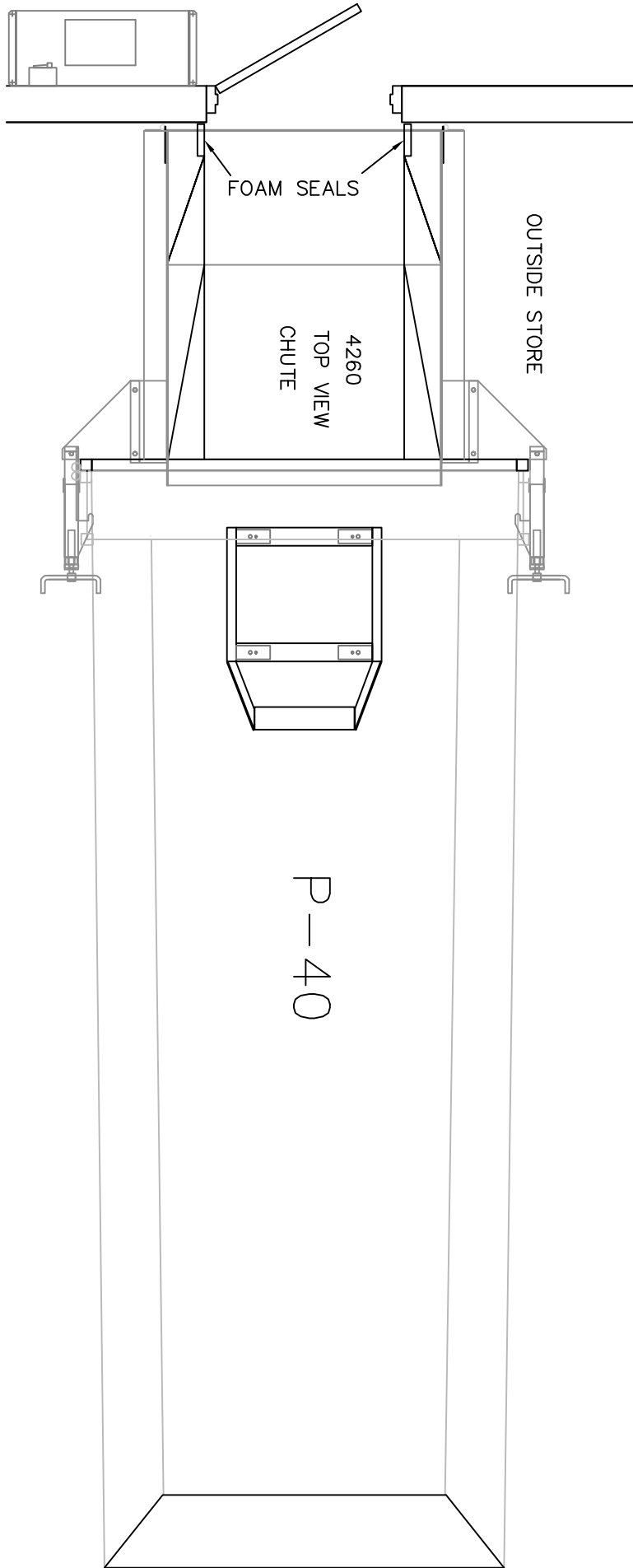

Product Data Sheet

NOCO MULTI-PURPOSE EP#2

NOCO MULTI-PURPOSE EP#2 is compatible with the most popular greases in use today, including Aluminum complex, calcium, calcium complex and lithium grease. It is not compatible with barium Ben tone or poly urea greases.

NOCO MULTI-PURPOSE EP#2 is multi-purpose, premium quality grease made from high viscosity Index base oils and a lithium complex soap thickener system. Because of its outstanding performance Properties, it can be used for the lubrication of machinery under heavy loads and high temperatures in a wide range of automotive, industrial, agricultural, mining and construction applications.

NOCO MULTI-PURPOSE EP#2 can be used to lubricate plain ball and roller bearings in equipment Operating from slow to high speeds and at temperatures ranging from -24°C (15°F) to 170°C (365°F).

TYPICAL PROPERTIES & CHARACTERISTICS

Test Methods	Description	Specification
	NLGI Grade	2
ASTM D 217	Cone penetration @ 77°F , worked 60 strokes	265 - 295
ASTM D 128	Thickener Type	Lithium Complex
ASTM D 128	Thickener Content, %	4 - 7
ASTM D 2265	Dropping Point	168°C , (360°F)
ASTM D 445	Base Oil Viscosity, cut @ 40°C	175 - 180
ASTM D 2270	Viscosity Index	80 min.
VISUAL	Color	Dark Amber
VISUAL	Appearance	Smooth
ASTM D 2509	Timkin OK Load, lbs.	35 min

Don't Pollute! Dispose or used oil properly!

Call your NOCO sales representative for details on our Oil Recovery Program

All reasonable care has been taken to ensure that the above information is accurate as of the date of printing.

NOCO Energy Corp.
Tonawanda, NY 14150
(800) 500-6626